

ORION BILEVEL MOTION SENSOR

G-22292 INSTALLATION INSTRUCTIONS

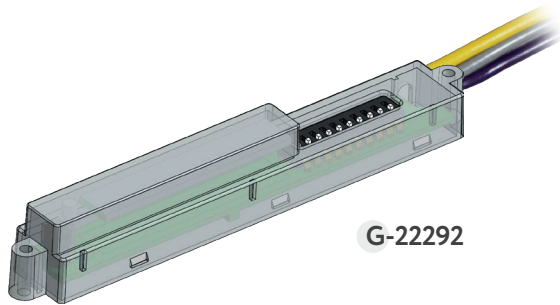

G-22292

SPECIFICATIONS	
Power Supply	12V .24 DC, >50mA
HF System	5.8GHz 75MHz
Dim control output	0-10V, max. 25mA sinking current
Detection radius/angle	Max 17ft. (5.2m)/360
Mounting height	Max 13ft(4m)
Remote range	50ft. (15m) indoor, no backlight
Humidity	Max. 95% RH
Temperature	-40 F ~ 158 F (-40 C ~ 70 C)

Installation Instructions

Press the lamp fixture in the direction of the arrows to detach it from the PC diffuser cover.
Push and separate the lamp fixture from the PC diffuser cover.

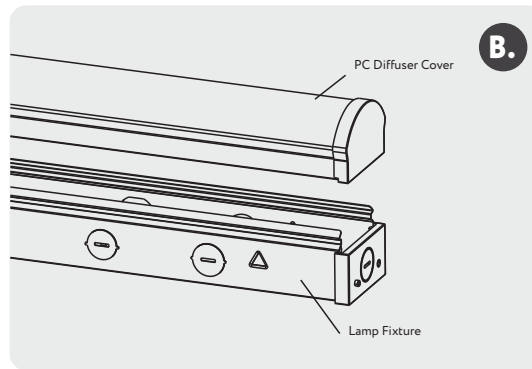
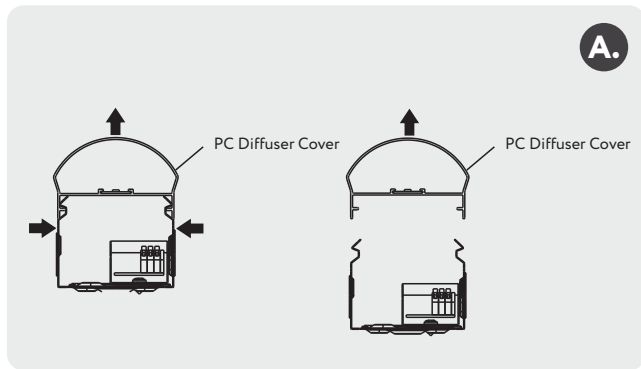

NOTE: The high-frequency output of this sensor is <0.2mW that is just one 5000th of the transmission power of a mobile phone or the output of a microwave oven.

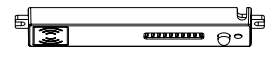

Transmission Power <0.2mW

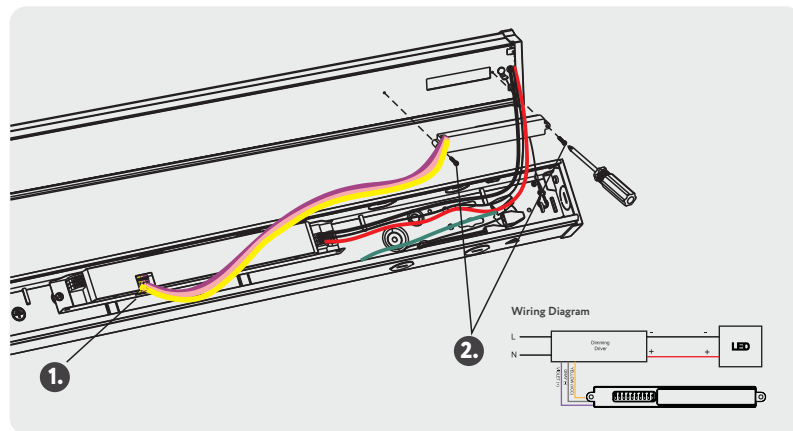

Step 1.

Connect the yellow, pink, and purple wires from the sensor to the matching colors on the of LED driver. Make sure to match each wire color with the corresponding terminal to avoid incorrect wiring.

Step 2.

Position the sensing device in the desired location and secure it firmly with the provided screws.

Warning

Warm up time is 15seconds. After the sensor connects input power first time, the light will keep on 15seconds,then go to dimming to work normally.
Factory Default Setting: 100% sensitivity, Hold on time: 10seconds, Daylight sensor is 30lux, Dimming level:30%, Dimming time: 60minutues.
Any setting changed by DIP Switch or remote control, the led light that sensor connect will on/off as confirm.

Utilizing Field and Introduction

G-22292 is a moving object sensor that can detect range of 360° and its working frequency is 5.8GHz. The advantage of this product is stable working state (stable working temperature: -40°C~+70°C), G-22292 adopts a microwave sensor (high-frequency output <0.2mW), so that it is safe and performs better than infrared sensor.

Function and Options

It offers 3 levels of the light Control : 100%--dimming light (0,10%,30%,50 %)--off; Periods of selectable waiting time: motion hold-time and 24hours, selectable daylight threshold, and freedom of detection area.

If natural light lower Light-control setting (10Lux,30Lux,50Lux), the light will not automatically on (0,10%,30%,50%). When person enter in the room, the light will on 100%, after person left the room, the room enter in stand by level after hold on time.

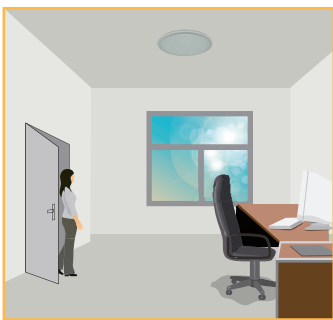

With sufficient natural light, the light does not switch on when presence detected.

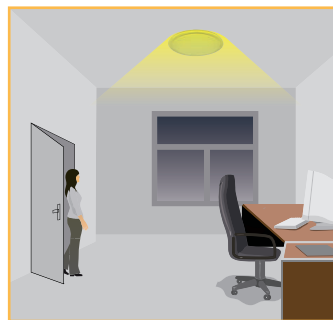

With insufficient natural light, the sensor switches on the light automatically when person enters the (options) standby level after the room. The lamp never switch off with presence, even the nature light is sufficient.

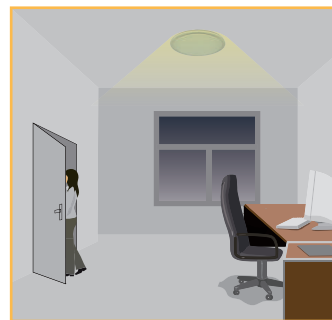

People left, light still dims to 0/10%/30%/50% (options) standby level after the hold time.



Light switches off automatically after the dimming time elapsed.

Sensor Coverage

Top View

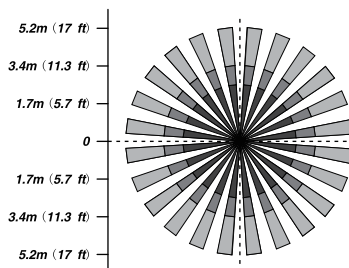

Side View

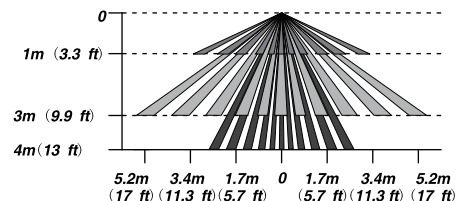

Consider the picture: 1, 2 set sensitivity; 3, 4 set hold time; 5, 6 set the lux; 7, 8 stand-by light level ; 9, 10 set stand-by time. See next page for details instructions

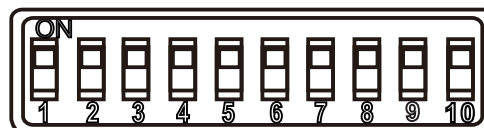

Detection Range Setting (Sensitivity)

Detection range can be reduced by selecting the combination on the DIP switches to fit precisely each application:

Sensitivity

1	2	
↓	↓	20%
↓	↑	50%
↑	↓	75%
↑	↑	100%

Hold Time Setting

The lamp can be set to stay ON for any period of time between approx. 10sec and a maximum of 15min. Any movement detected before this time elapse will re-start the timer. It is recommended to select the shortest time for adjusting the detection zone and for performing the walk test. Switch location and hold time of the corresponding table is as follows:

Time

3	4	
↓	↓	10S
↓	↑	1Min
↑	↓	5Min
↑	↑	15Min

Light-control Setting

The chosen lamp response threshold can be infinitely from approx. 10-50Lux, switch location and light-control of the corresponding table is as follows

Light

5	6	
↓	↓	☀ (light sensor disable)
↓	↑	10Lux
↑	↓	30Lux
↑	↑	50Lux

Stand-By Light Level Setting

The corresponding file of switch location and stand-by level as follow:

Stand-By Level

7	8	
↓	↓	0%
↓	↑	10%
↑	↓	30%
↑	↑	50%

Light-control Setting

The corresponding file of switch location and stand-by time setting as follow:

STAND-BY TIME

9	10	
↓	↓	+∞
↓	↑	1Min
↑	↓	30Min
↑	↑	60Min

Parameter Setting By Remote Control In Manual Of Rc-100.

Wiring Diagram

G-22292 wiring with dimming ballast or LED driver.

